

ISTRUZIONI DI MONTAGGIO ASSEMBLY INSTRUCTIONS

MODELLO:
MODEL:

411/78.1990.25
411/78.1990.25P

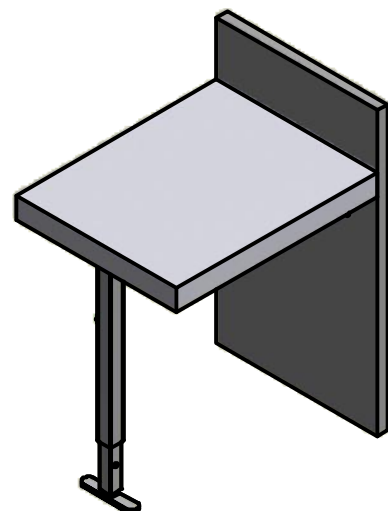

CONTENUTO DELLA CONFEZIONE INCLUDED IN THE PACKAGING

GAMBA
LEGS

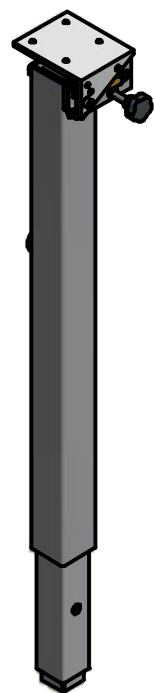

411/78.1990.25
SACCHETTO ACCESSORI - ACCESSORIES

- A. Chiave esa. n.5 - n.5 Allen key
- B. Chiave esa. n.4 - n.4 Allen key
- C. Chiave esa. n.3 - n.3 Allen key
- D. Bussola M5 - M5 bush (x 4)
- E. Vite TPS M5x16 - M5x16 FHCS screw (x 4)
- F. Vite TPS M6x16 - M6x16 FHCS screw (x 2)
- G. Blumotion - Blumotion (x 2)
- H. Paracolpi - Dumper (x 2)

411/78.1990.25P
SACCHETTO ACCESSORI - ACCESSORIES

- I. Bussola M5 - M5 bush (x 4)
- II. Vite TCB M5x20 - M5x20 BHCS screw (x 4)
- III. Spessore - Thickness (x 2)
- IV. Cavallotto - Jumper (x 2)
- V. Perno - Pin (x 2)
- VI. Anello - Ring (x 2)

PIEDE
FOOT



DIMENSIONI GENERALI GENERAL DIMENSIONS

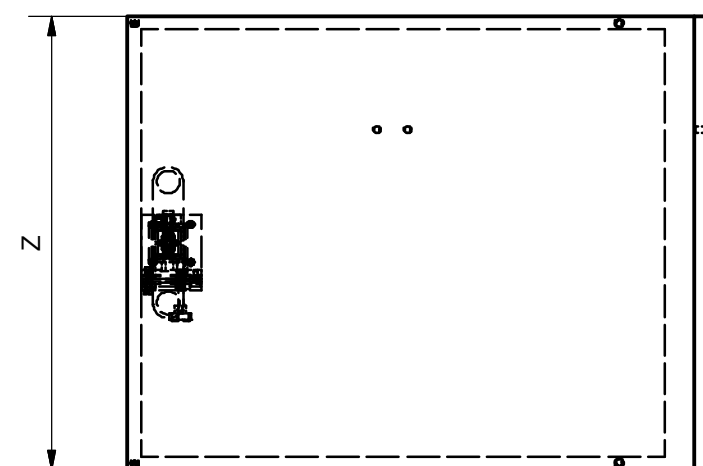
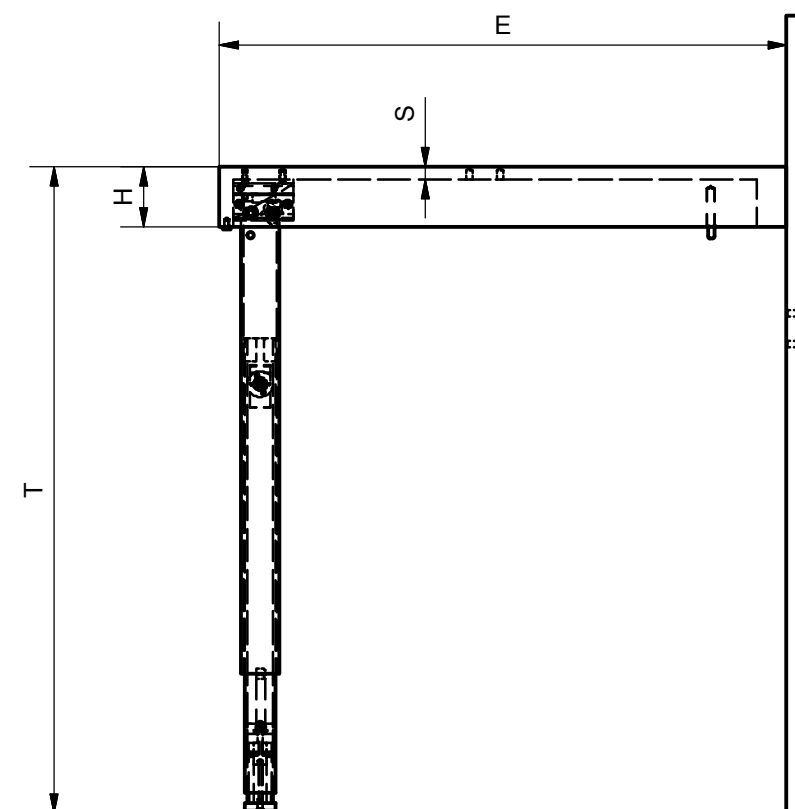

DIMENSIONE - DIMENSION	SIMBOLO - SYMBOL	mm
ALTEZZA - HEIGHT	H	MIN: 80
SPESSORI PIANO - TOP THICKNESS	S	MIN: 18
LARGHEZZA PIANO - TOP WIDTH	Z	MIN: 600
APERTURA PIANO - TOP OPENING	E	750
ALTEZZA MECCANISMO - HEIGHT MECHANISM	T	855

MONTAGGIO DEL MECCANISMO MOUNTING OF THE MECHANISM

SEQUENZA DI FUNZIONAMENTO FUNCTIONING STEPS

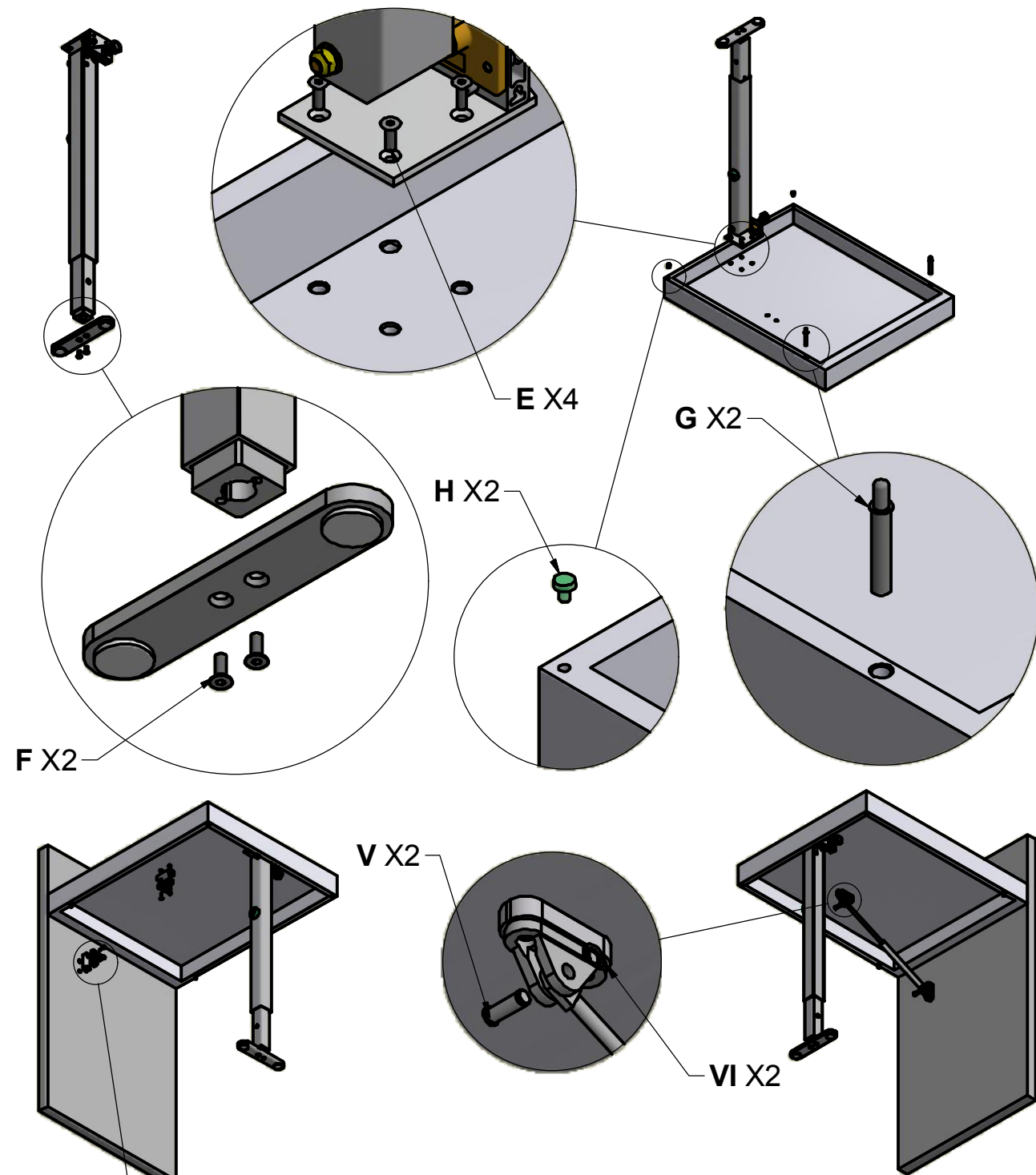

411/78.1990.25
SACCHETTO ACCESSORI - ACCESSORIES

- A. Chiave esa. n.5 - n.5 Allen key
- B. Chiave esa. n.4 - n.4 Allen key
- C. Chiave esa. n.3 - n.3 Allen key
- D. Bussola M5 - M5 bush (x 4)
- E. Vite TPS M5x16 - M5x16 FHCS screw (x 4)
- F. Vite TPS M6x16 - M6x16 FHCS screw (x 2)
- G. Blumotion - Blumotion (x 2)
- H. Paracolpi - Dumper (x 2)

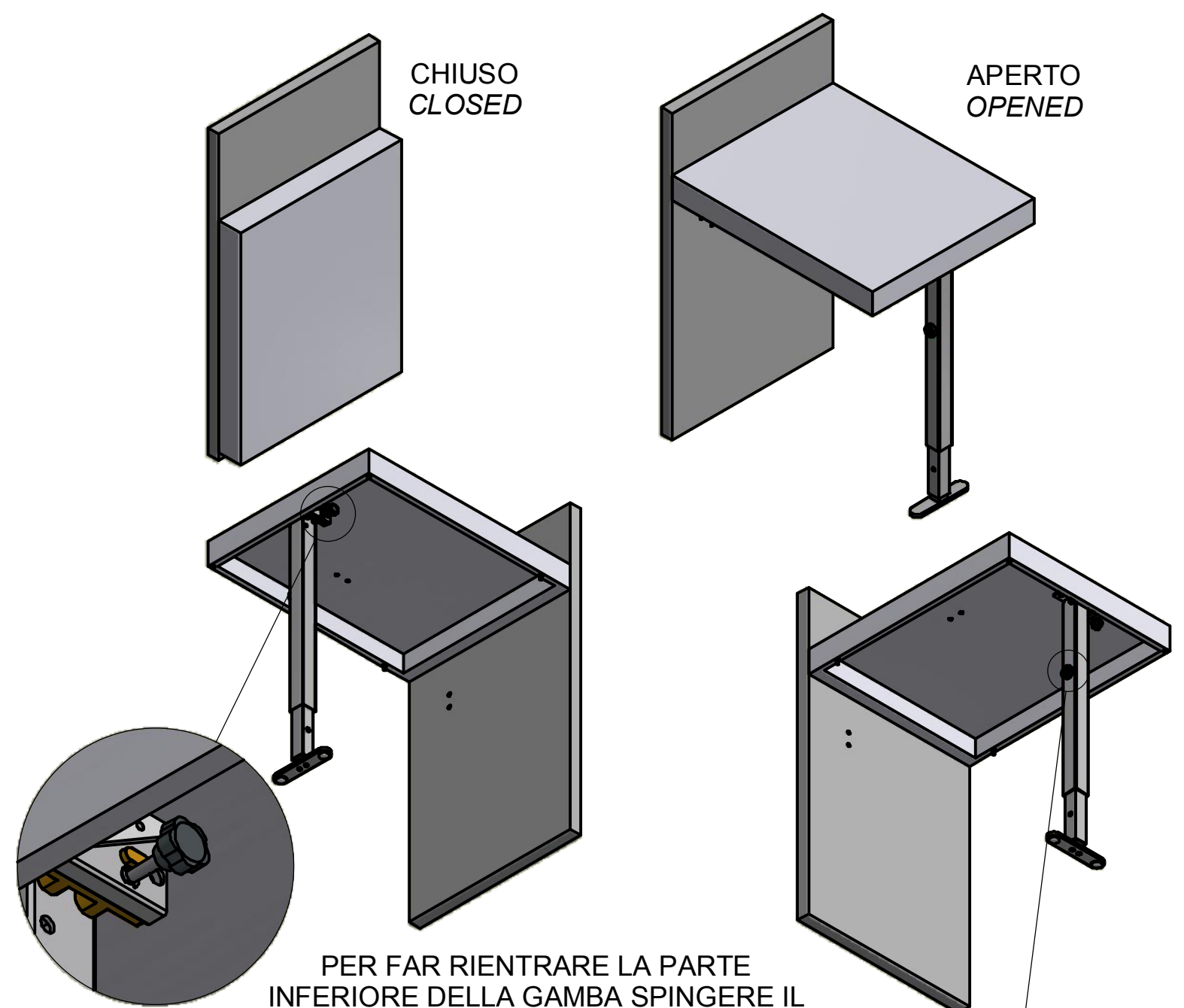

PER FAR RIENTRARE LA PARTE INFERIORE DELLA GAMBA SPINGERE IL PULSANTE INDICATO
TO CLOSE THE INFERIOR PART OF THE LEG, PUSH THE INDICATE BUTTON.

411/78.1990.25P
SACCHETTO ACCESSORI - ACCESSORIES

- I. Bussola M5 - M5 bush (x 4)
- II. Vite TCB M5x20 - M5x20 BHCS screw (x 4)
- III. Spessore - Thickness (x 2)
- IV. Cavallotto - Jumper (x 2)
- V. Perno - Pin (x 2)
- VI. Anello - Ring (x 2)

PER RUOTARE LA GAMBA TIRARE IL POMELLO NERO
TO ROTATE THE LEG, PULL THE BLACK KNOB